

PROJECT: BUNCOMBE COUNTY - ASHEVILLE - PATTON AVENUE/US 19/US 23/US 74 ALT



# PROPOSED HIGHWAY LANDSCAPE DEVELOPMENT PROJECT



T.I.P. #	STATE PROJECT W.B.S. #	SHEET #	TOTAL SHEETS
	3713.3.27	1	8
FED. PROJ. #	DESCRIPTION	DIVISION	
	PATTON AVE ASHEVILLE	13	

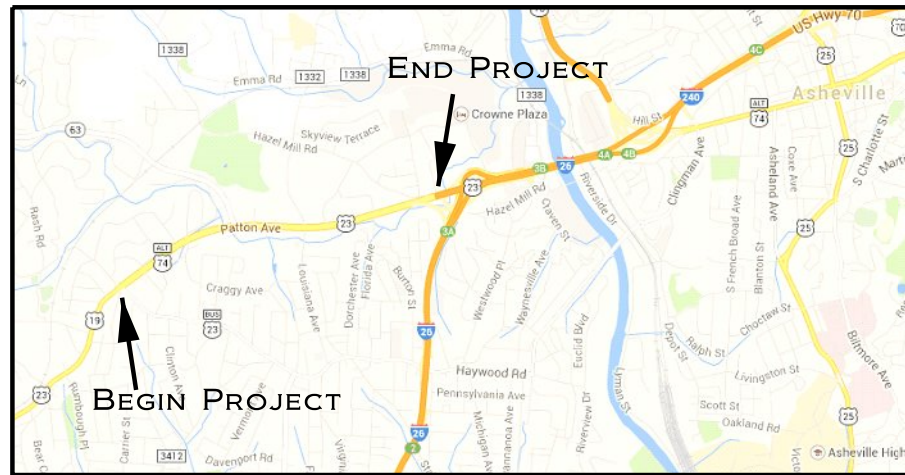

VICINITY MAP



PROJECT LOCATION

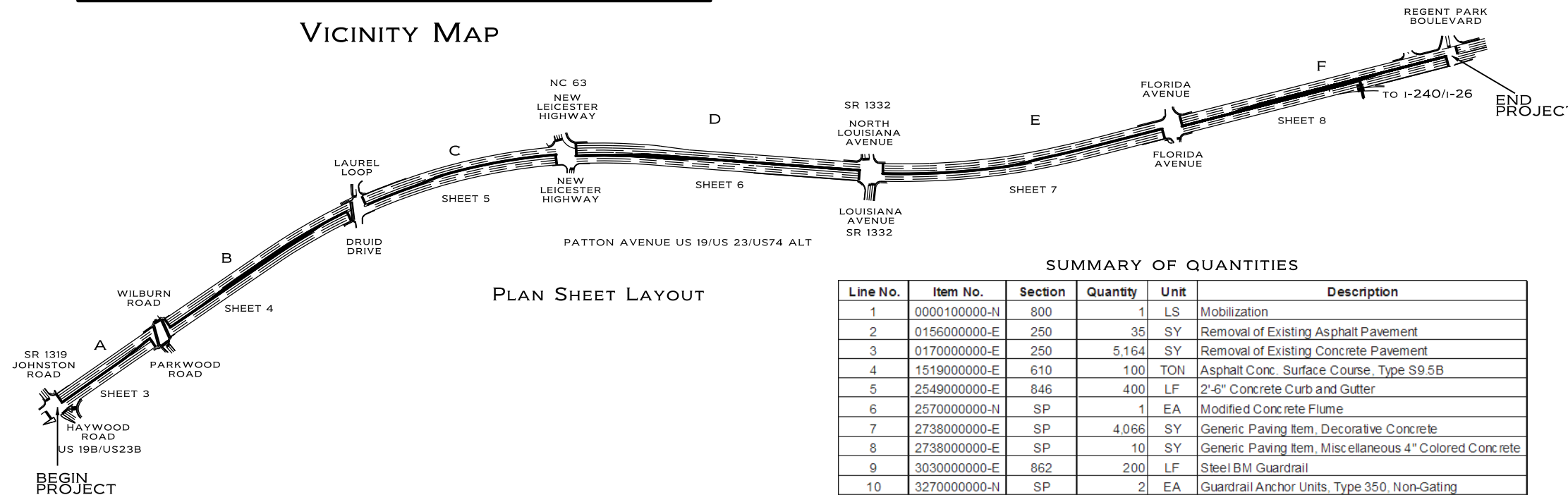

PLAN SHEET LAYOUT

CONVENTIONAL SYMBOLS

- County Line
- City or Town Line
- Exist. Right of Way Line Marker
- Prop. Right of Way Line Marker (By Others)
- Prop Right of Way Line Marker (By Contract)
- Exist. Control of Access Line
- Prop. Control of Access Line
- Property Line
- Easement Line
- Slope Stake Line
- Exist. Fence
- Prop. Woven Wire Fence
- Prop. Chain Link Fence
- Exist. Road
- Prop. Road
- Guardrail
- Survey Line
- Denotes Line Equality
- Bridge
- Culvert
- Railroad
- Woods
- Exist. Telephone Pole
- Prop. Telephone Pole
- Tower Pole and Line
- Exist. Power Pole
- Prop. Power Pole
- Sanitary Sewer Line
- Water Line
- Gas Line
- Picnic Shelter
- Regeneration
- Reforestation

INDEX OF L SHEETS:

- 1 ..... TITLE, DESCRIPTION AND SHEET LAYOUT
- 2 ..... DETAILS
- 3-8 ..... PLANS

PREPARED BY: CSM  
 PRELIMINARY DESIGN DATE: AUGUST, 2014  
 FINAL DESIGN DATE: FEBRUARY 24, 2015  
 REVISION DATE: JUNE 9, 2015

PATTON AVENUE FROM HAYWOOD RD TO REGENT PARK RD

SUMMARY OF QUANTITIES

Line No.	Item No.	Section	Quantity	Unit	Description
1	0000100000-N	800	1	LS	Mobilization
2	0156000000-E	250	35	SY	Removal of Existing Asphalt Pavement
3	0170000000-E	250	5,164	SY	Removal of Existing Concrete Pavement
4	1519000000-E	610	100	TON	Asphalt Conc. Surface Course, Type S9.5B
5	2549000000-E	846	400	LF	2'-6" Concrete Curb and Gutter
6	2570000000-N	SP	1	EA	Modified Concrete Flume
7	2738000000-E	SP	4,066	SY	Generic Paving Item, Decorative Concrete
8	2738000000-E	SP	10	SY	Generic Paving Item, Miscellaneous 4" Colored Concrete
9	3030000000-E	862	200	LF	Steel BM Guardrail
10	3270000000-N	SP	2	EA	Guardrail Anchor Units, Type 350, Non-Gating
11	4405000000-E	1,110	126	SF	Work Zone Signs (Portable)
12	4457000000-N	SP	1	LS	Temporary Traffic Control
13	4510000000-N	SP	160	HR	Law Enforcement
14	5255000000-N	1,413	1	LS	Portable Lighting
15		SP	610	CY	Removal of Subsoil in Plant Beds
17		SP	670	CY	Topsoil
16		SP	1	LS	Landscape Grading
18		1,670	67	CY	Mulch for Planting

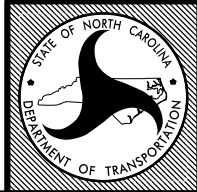

STATE OF NORTH CAROLINA  
 DEPARTMENT OF TRANSPORTATION

LOCATION: PATTON AVENUE FROM HAYWOOD ROAD TO REGENT PARK ROAD - ASHEVILLE  
 TYPE OF WORK: LANDSCAPING - HARDSCAPE  
 COUNTY: BUNCOMBE COUNTY

DIVISION 13

2004 AMERICAN STANDARD FOR NURSERY STOCK  
 2012 NCDOT STANDARD SPECIFICATIONS  
 PREPARED IN THE OFFICE OF:  
 NCDOT- ROADSIDE ENVIRONMENTAL UNIT  
 AESTHETIC ENGINEERING SECTION  
 1557 MAIL SERVICE CENTER  
 RALEIGH NC 27699 919-707-2920

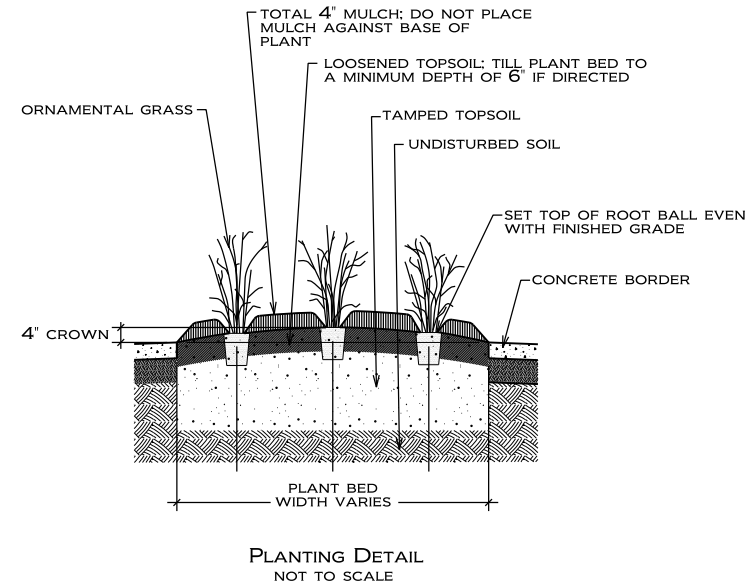
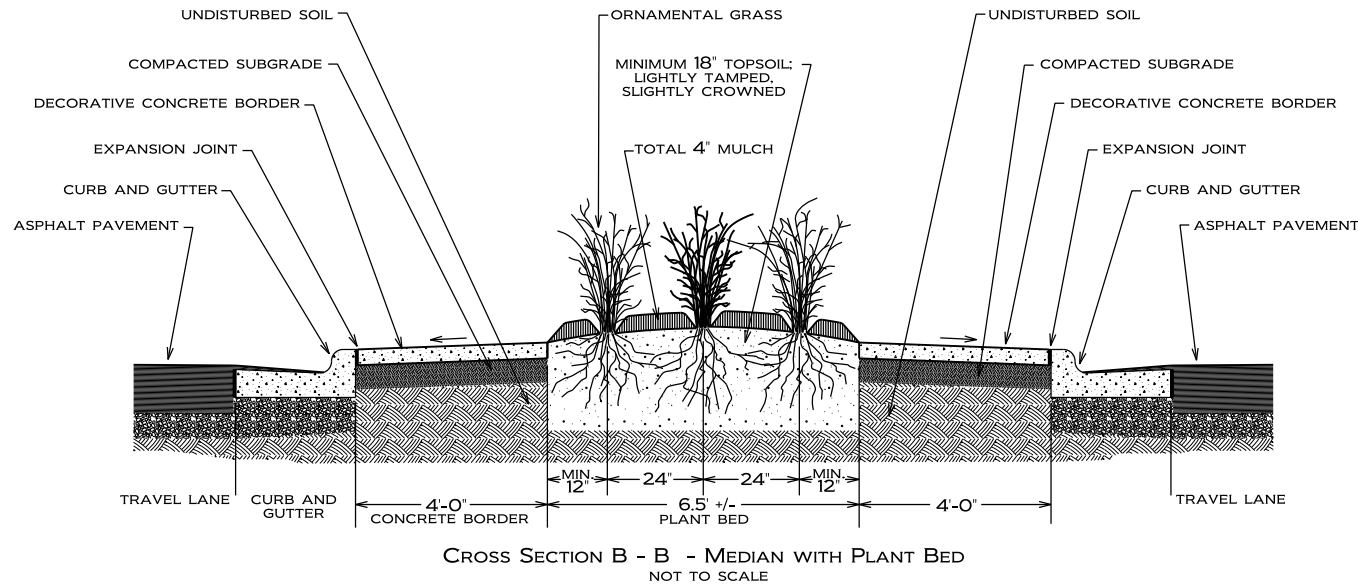

DECORATIVE CONCRETE SHALL HAVE AN OLD COBBLESTONE PATTERN AND TEXTURE STAMPED INTO THE CONCRETE. THE PATTERN SHOULD RUN PARALLEL TO THE CURB AS MUCH AS POSSIBLE. EXACT LAYOUT SHALL BE APPROVED BY THE LANDSCAPE DESIGNER AND ENGINEER PRIOR TO BEGINNING POUR OF EACH MEDIAN SECTION. COLOR SHALL BE INTEGRAL IN MIX WITH A SURFACE TREATMENT TO ACHIEVE AN ANTIQUING EFFECT.

JOINT LOCATIONS SHALL BE DISCUSSED, AND APPROVED BY THE LANDSCAPE DESIGNER AND ENGINEER PRIOR TO BEGINNING POUR OF EACH MEDIAN SECTION. CONTRACTION JOINTS SHALL BE LOCATED EVERY 5 TO 8 FEET. CONSTRUCTION JOINTS SHALL BE LOCATED EVERY 50 TO 56 FEET AND SHALL BE DOWELED OR KEYS. INSTALL EXPANSION JOINTS ALONG ALL CURB AND EXISTING STRUCTURES.

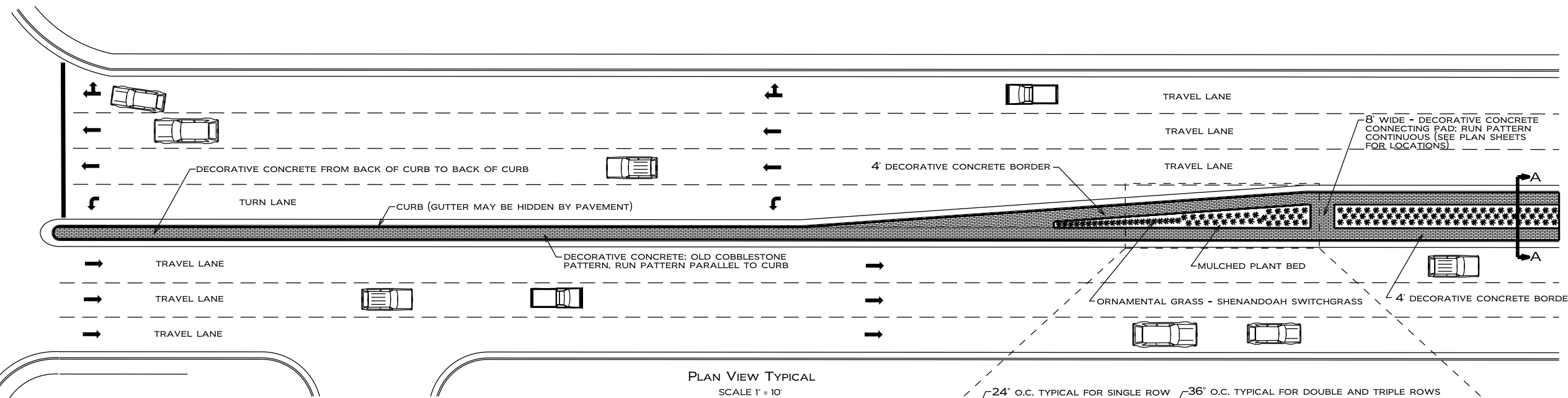

PLAN VIEW TYPICAL  
SCALE 1" = 10'

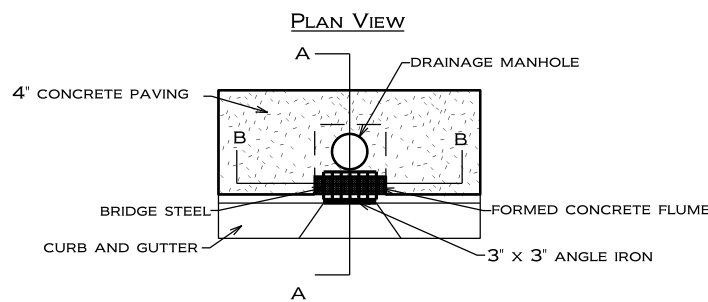

FORMED CONCRETE FLUME WITH BRIDGE STEEL CONCRETE PAVING SUPPORT  
NOT TO SCALE

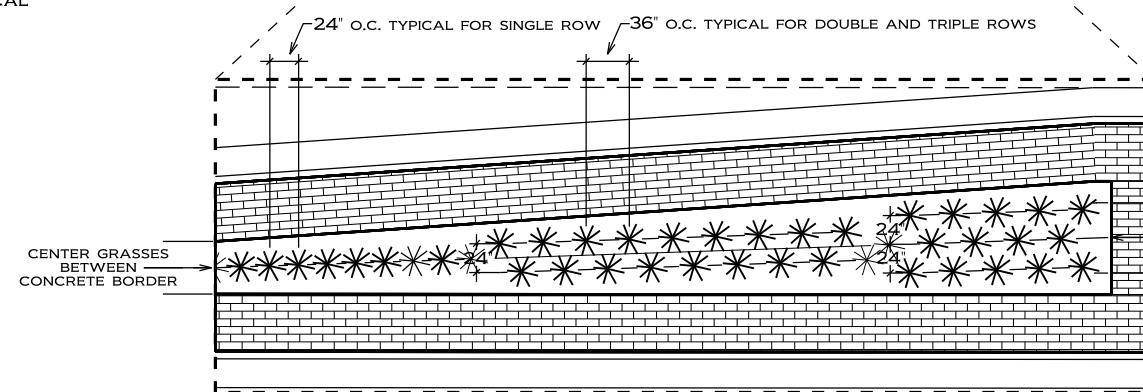
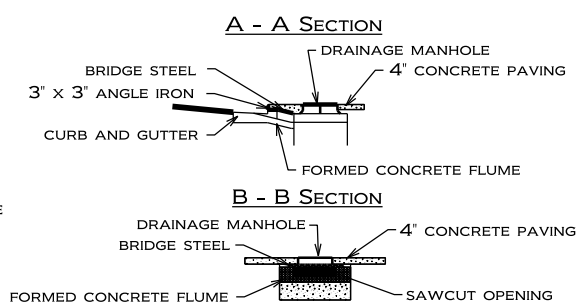

PLANTING LAYOUT  
NOT TO SCALE



NCDOT - ROADSIDE ENVIRONMENTAL UNIT  
AESTHETIC ENGINEERING SECTION  
1557 MAIL SERVICE CENTER RALEIGH NC 27699-1557  
PHONE: 919-707-2920 FAX: 919-715-2554

HTTP://WWW.NCDOT.ORG/DOH/OPERATIONS/DP\_CHIEF\_ENG/ROADSIDE/

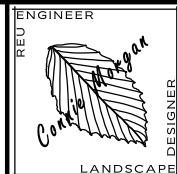

PATTON AVENUE US 23 / US 74 ALTERNATE  
FROM HAYWOOD ROAD TO REGENT PARK BOULEVARD  
MEDIAN ENHANCEMENT  
ASHEVILLE - BUNCOMBE COUNTY

SHEET DESCRIPTION:

LANDSCAPE DEVELOPMENT  
HARDSCAPE  
DETAILS AND LAYOUT

PRELIMINARY DESIGN DATE: AUGUST 15, 2014  
FINAL DESIGN DATE: FEBRUARY 24, 2015

PROJECT: PATTON AVENUE  
MEDIAN ENHANCEMENT

DIVISION AND COUNTY:  
DIVISION 13 - BUNCOMBE

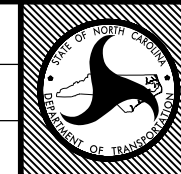

SHEET NO: 2

TOTAL SHEET NO: 8

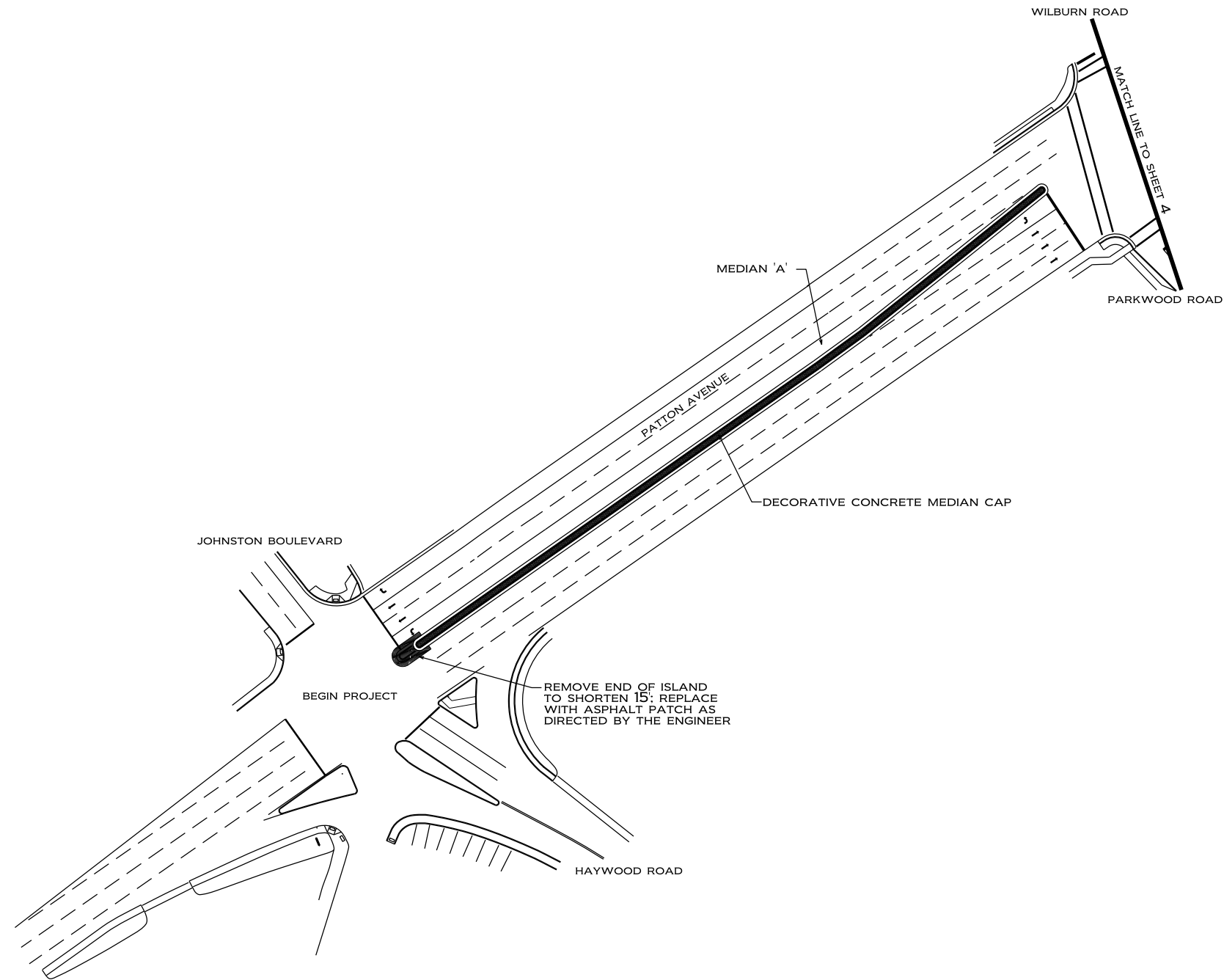

TOTAL DECORATIVE CONCRETE FOR MEDIAN A APPROXIMATELY 2118 SF



NCDOT - ROADSIDE ENVIRONMENTAL UNIT  
**AESTHETIC ENGINEERING SECTION**  
 1557 MAIL SERVICE CENTER RALEIGH NC 27699-1557  
 PHONE: 919-707-2920 FAX: 919-715-2554  
[HTTP://WWW.NCDOT.ORG/DOH/OPERATIONS/DP\\_CHIEF\\_ENG/ROADSIDE/](http://www.ncdot.org/doh/operations/dp_chief_eng/roadside/)

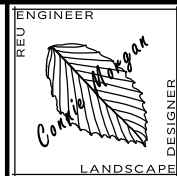

**PATTON AVENUE US 23 / US 74 ALTERNATE**  
**FROM HAYWOOD ROAD TO REGENT PARK BOULEVARD**  
**MEDIAN ENHANCEMENT**  
**ASHEVILLE - BUNCOMBE COUNTY**

SHEET DESCRIPTION:  
 LANDSCAPE DEVELOPMENT  
 HARDSCAPE  
 MEDIAN 'A' PLAN

PRELIMINARY DESIGN DATE : AUGUST 15, 2014  
 FINAL DESIGN DATE : FEBRUARY 24, 2015  
 FINAL DESIGN DATE : JUNE 9, 2015  
 PROJECT: PATTON AVENUE  
 MEDIAN ENHANCEMENT  
 DIVISION AND COUNTY:  
 DIVISION 13 - BUNCOMBE

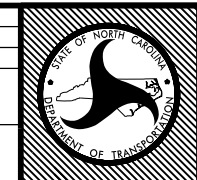

SHEET NO : 3  
 TOTAL SHEET NO : 8

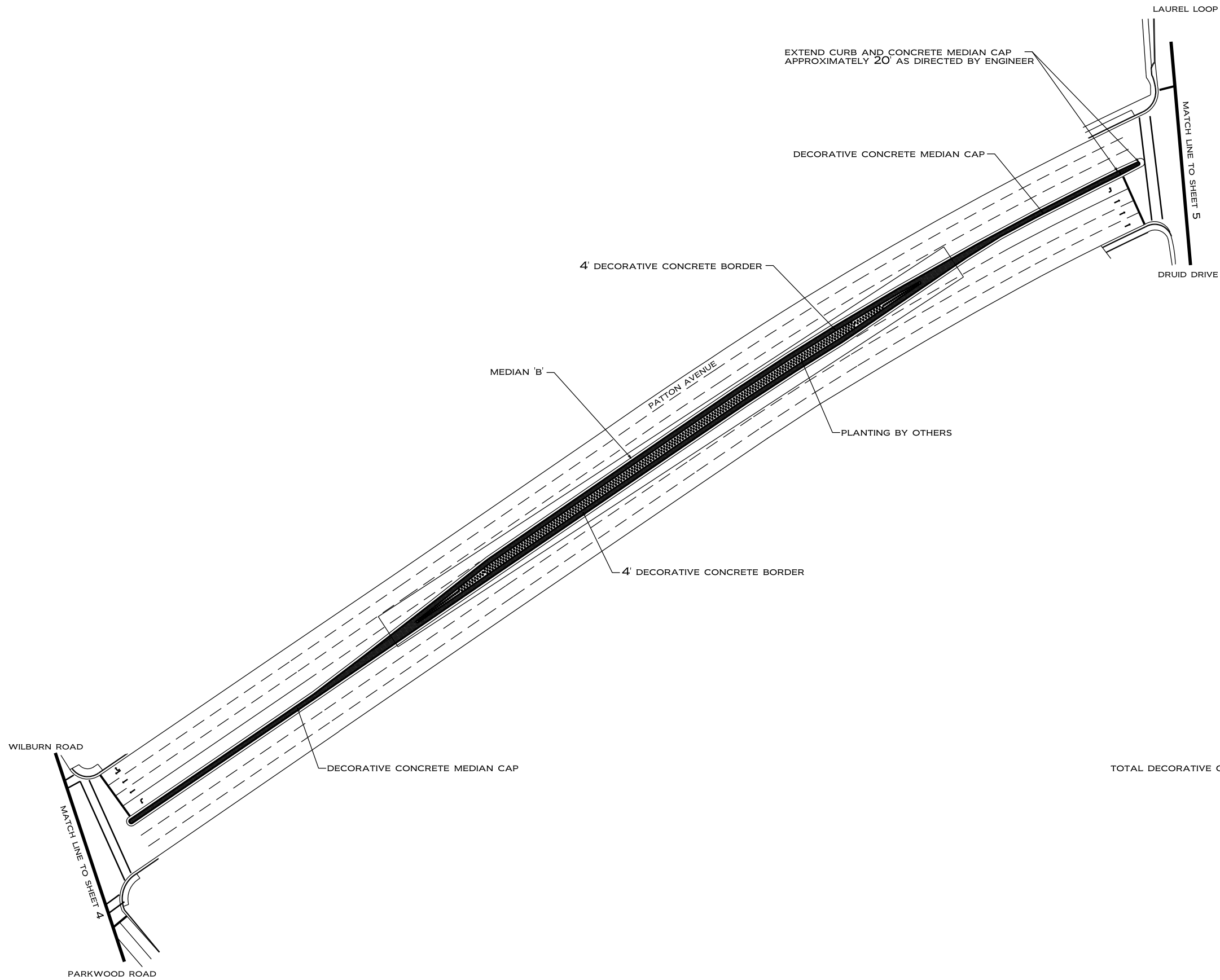

TOTAL DECORATIVE CONCRETE FOR MEDIAN B APPROXIMATELY 7158 SF

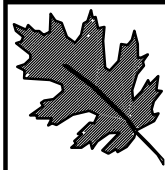
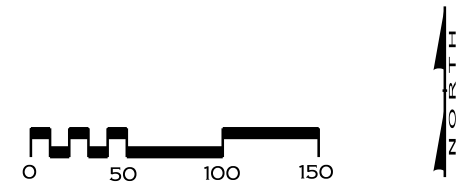

NCDOT - ROADSIDE ENVIRONMENTAL UNIT  
**AESTHETIC ENGINEERING SECTION**  
 1557 MAIL SERVICE CENTER RALEIGH NC 27699-1557  
 PHONE: 919-707-2920 FAX: 919-715-2554  
[HTTP://WWW.NCDOT.ORG/DOH/OPERATIONS/DP\\_CHIEF\\_ENG/ROADSIDE/](http://www.ncdot.org/doh/operations/dp_chief_eng/roadside/)

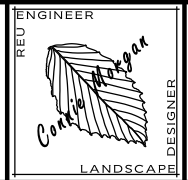

**PATTON AVENUE US 23 / US 74 ALTERNATE**  
**FROM HAYWOOD ROAD TO REGENT PARK BOULEVARD**  
**MEDIAN ENHANCEMENT**  
**ASHEVILLE - BUNCOMBE COUNTY**

SHEET DESCRIPTION:  
 LANDSCAPE DEVELOPMENT  
 HARDSCAPE  
**MEDIAN 'B' PLAN**

PRELIMINARY DESIGN DATE: AUGUST 15, 2014 FINAL DESIGN DATE: FEBRUARY 24, 2015  
 PROJECT: **PATTON AVENUE MEDIAN ENHANCEMENT**  
 DIVISION AND COUNTY: **DIVISION 13 - BUNCOMBE**

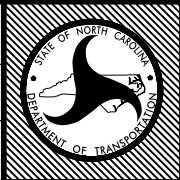

SHEET NO : 4  
 TOTAL SHEET NO : 8

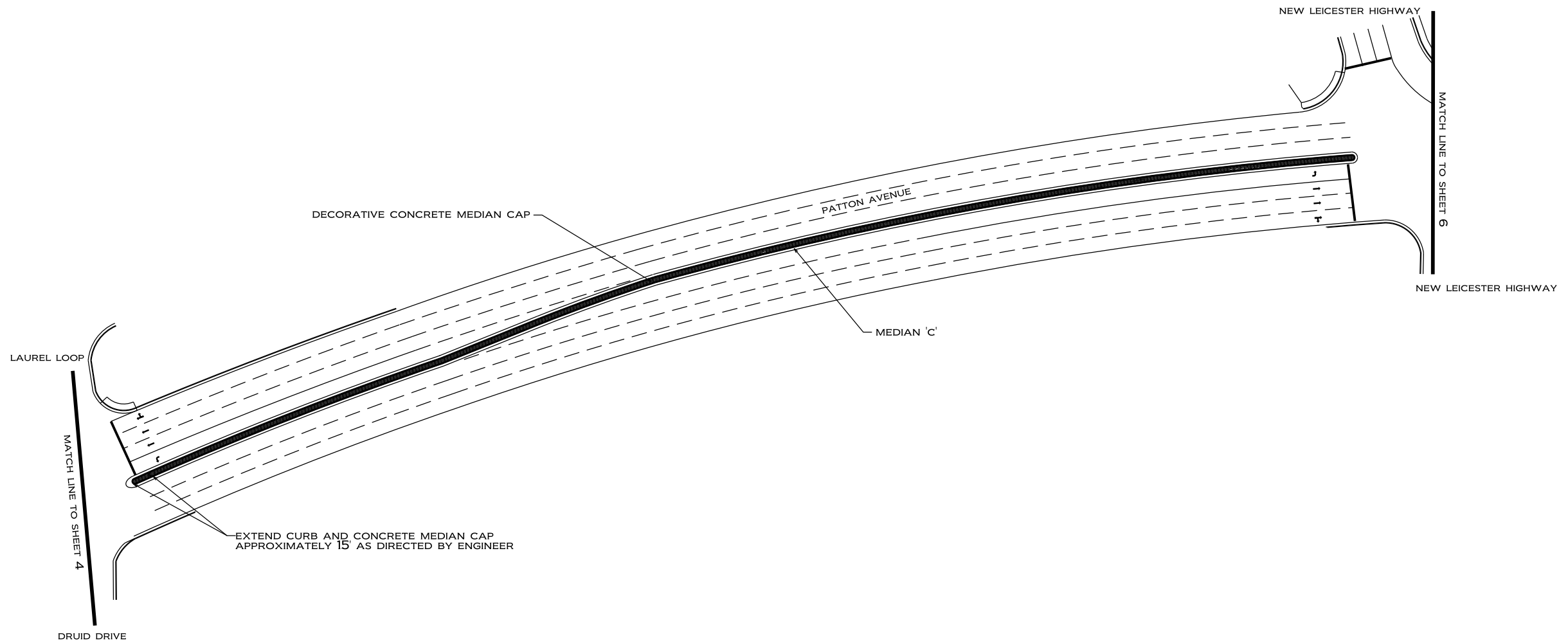

TOTAL DECORATIVE CONCRETE FOR MEDIAN C APPROXIMATELY 4124 SF

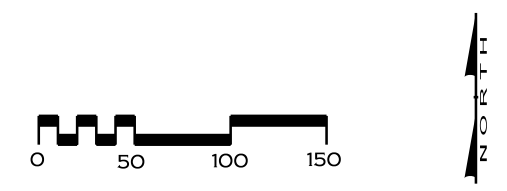

NCDOT - ROADSIDE ENVIRONMENTAL UNIT  
**AESTHETIC ENGINEERING SECTION**  
 1557 MAIL SERVICE CENTER RALEIGH NC 27699-1557  
 PHONE: 919-707-2920 FAX: 919-715-2554  
[HTTP://WWW.NCDOT.ORG/DOH/OPERATIONS/DP\\_CHIEF\\_ENG/ROADSIDE/](http://www.ncdot.org/doh/operations/dp_chief_eng/roadside/)

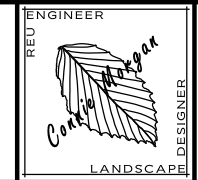

**PATTON AVENUE US 23 / US 74 ALTERNATE**  
**FROM HAYWOOD ROAD TO REGENT PARK BOULEVARD**  
**MEDIAN ENHANCEMENT**  
**ASHEVILLE - BUNCOMBE COUNTY**

SHEET DESCRIPTION:  
 LANDSCAPE DEVELOPMENT  
 HARDSCAPE  
 MEDIAN 'C' PLAN

PRELIMINARY DESIGN DATE: AUGUST 15, 2014 FINAL DESIGN DATE: FEBRUARY 24, 2015  
 PROJECT: PATTON AVENUE MEDIAN ENHANCEMENT  
 DIVISION AND COUNTY: DIVISION 13 - BUNCOMBE

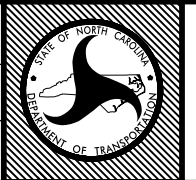

SHEET NO : 5  
 TOTAL SHEET NO : 8

NEW LEICESTER HIGHWAY

MATCH LINE TO SHEET 5

NEW LEICESTER HIGHWAY

DECORATIVE CONCRETE MEDIAN CAP

4' DECORATIVE CONCRETE BORDER

MEDIAN 'D'

PLANTING BY OTHERS

4' DECORATIVE CONCRETE BORDER

PATTON AVENUE

DECORATIVE CONCRETE MEDIAN CAP

NORTH LOUISIANA AVENUE

MATCH LINE TO SHEET 7

LOUISIANA AVENUE

TOTAL DECORATIVE CONCRETE FOR MEDIAN D APPROXIMATELY 7624 SF

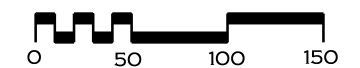

N  
↑  
H  
R  
O  
N



NCDOT - ROADSIDE ENVIRONMENTAL UNIT  
**AESTHETIC ENGINEERING SECTION**  
 1557 MAIL SERVICE CENTER RALEIGH NC 27699-1557  
 PHONE: 919-707-2920 FAX: 919-715-2554

[HTTP://WWW.NCDOT.ORG/DOH/OPERATIONS/DP\\_CHIEF\\_ENG/ROADSIDE/](http://www.ncdot.org/doh/operations/dp_chief_eng/roadside/)

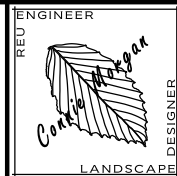

**PATTON AVENUE US 23 / US 74 ALTERNATE**  
**FROM HAYWOOD ROAD TO REGENT PARK BOULEVARD**  
**MEDIAN ENHANCEMENT**  
**ASHEVILLE - BUNCOMBE COUNTY**

SHEET DESCRIPTION:

LANDSCAPE DEVELOPMENT  
HARDSCAPE

MEDIAN 'D' PLAN

PRELIMINARY DESIGN DATE: AUGUST 15, 2014  
 FINAL DESIGN DATE: FEBRUARY 24, 2015

PROJECT: PATTON AVENUE  
 MEDIAN ENHANCEMENT

DIVISION AND COUNTY:  
 DIVISION 13 - BUNCOMBE

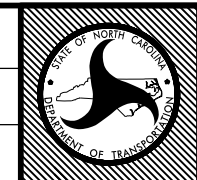

SHEET NO : 6

TOTAL SHEET NO : 8

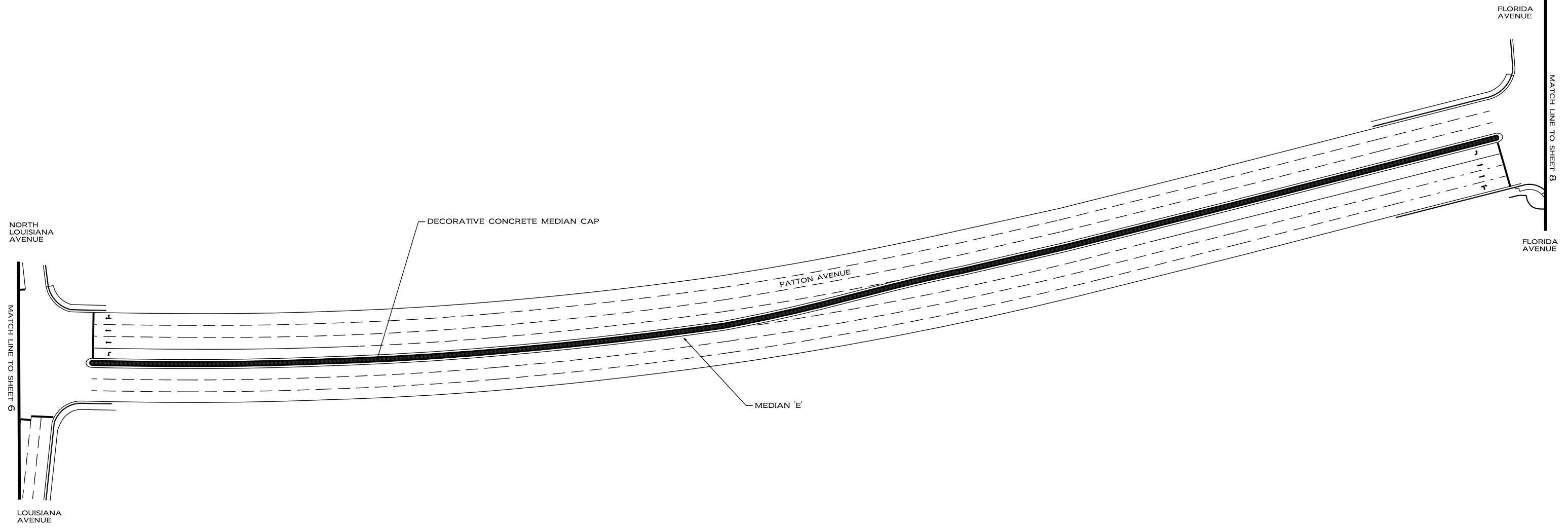

TOTAL DECORATIVE CONCRETE FOR MEDIAN E APPROXIMATELY 6442 SF



NCDOT - ROADSIDE ENVIRONMENTAL UNIT  
**AESTHETIC ENGINEERING SECTION**  
 1557 MAIL SERVICE CENTER RALEIGH NC 27699-1557  
 PHONE: 919-707-2920 FAX: 919-715-2554  
[HTTP://WWW.NCDOT.ORG/DOH/OPERATIONS/DP\\_CHIEF\\_ENG/ROADSIDE/](http://www.ncdot.org/doh/operations/dp_chief_eng/roadside/)

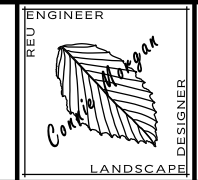

**PATTON AVENUE US 23 / US 74 ALTERNATE**  
**FROM HAYWOOD ROAD TO REGENT PARK BOULEVARD**  
**MEDIAN ENHANCEMENT**  
**ASHEVILLE - BUNCOMBE COUNTY**

SHEET DESCRIPTION:  
 LANDSCAPE DEVELOPMENT  
 HARDSCAPE  
**MEDIAN 'E' PLAN**

PRELIMINARY DESIGN DATE: AUGUST 15, 2014 FINAL DESIGN DATE: FEBRUARY 24, 2015  
 PROJECT: **PATTON AVENUE MEDIAN ENHANCEMENT**  
 DIVISION AND COUNTY: **DIVISION 13 - BUNCOMBE**

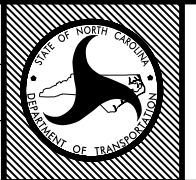

SHEET NO : 7  
 TOTAL SHEET NO : 8

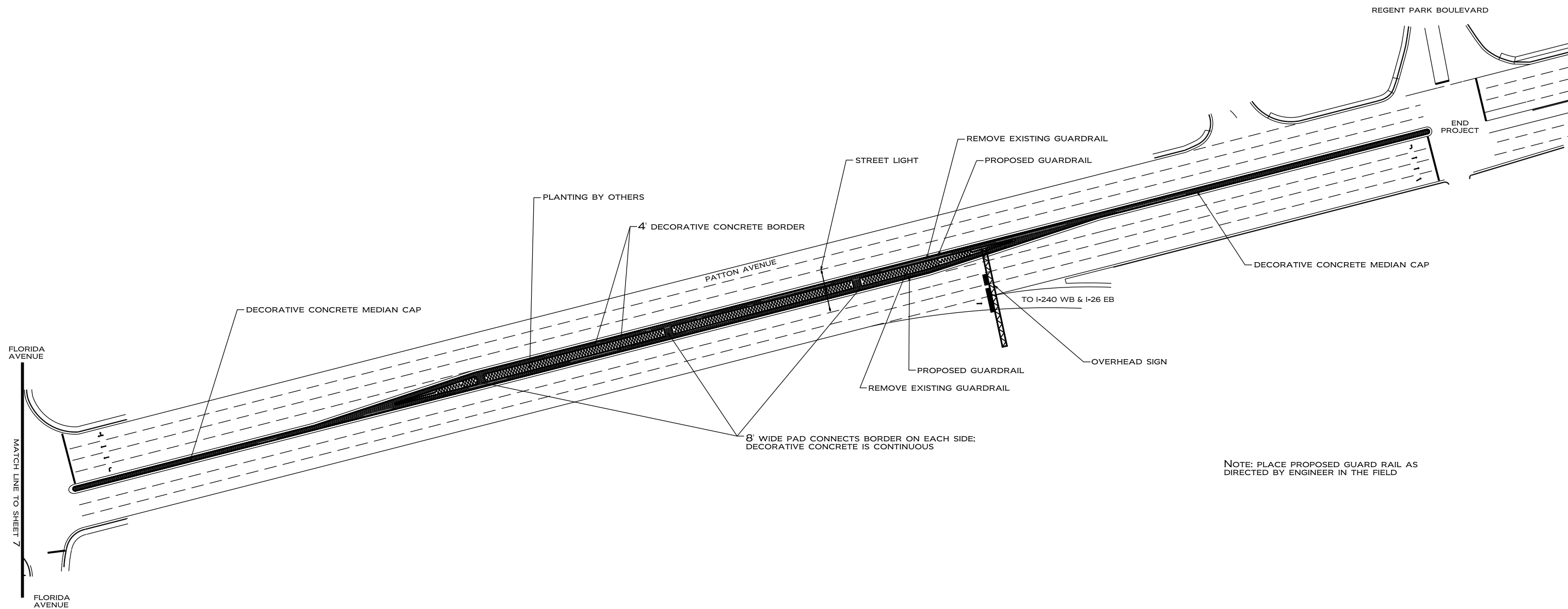

TOTAL DECORATIVE CONCRETE FOR MEDIAN E APPROXIMATELY 9125 SF

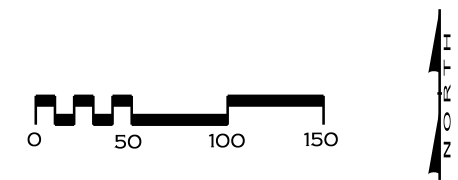

NCDOT - ROADSIDE ENVIRONMENTAL UNIT  
**AESTHETIC ENGINEERING SECTION**  
 1557 MAIL SERVICE CENTER RALEIGH NC 27699-1557  
 PHONE: 919-707-2920 FAX: 919-715-2554  
[HTTP://WWW.NCDOT.ORG/DOH/OPERATIONS/DP\\_CHIEF\\_ENG/ROADSIDE/](http://www.ncdot.org/doh/operations/dp_chief_eng/roadside/)

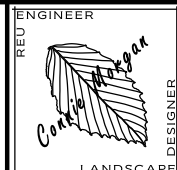

**PATTON AVENUE US 23 / US 74 ALTERNATE**  
**FROM HAYWOOD ROAD TO REGENT PARK BOULEVARD**  
**MEDIAN ENHANCEMENT**  
**ASHEVILLE - BUNCOMBE COUNTY**

SHEET DESCRIPTION:

LANDSCAPE DEVELOPMENT  
 HARDSCAPE  
 MEDIAN 'F' PLAN

PRELIMINARY DESIGN DATE: AUGUST 15, 2014 FINAL DESIGN DATE: FEBRUARY 24, 2015  
 PROJECT: PATTON AVENUE  
 MEDIAN ENHANCEMENT  
 DIVISION AND COUNTY:  
 DIVISION 13 - BUNCOMBE

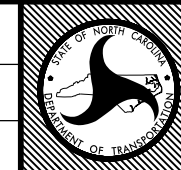

SHEET NO : 8  
 TOTAL SHEET NO : 8